

**NOTES:**

- 1.1 Drawing for reference only.
- 1.2 Product must conform to the dimensions/tolerances shown and to the data file.  
For data file refer to 3D model 4G0979.ROUND.prt.  
IF IN DOUBT REQUEST CLARIFICATION FROM GALLAGHER GROUP LTD.
- 1.3 Part must meet the requirements of the European Directive 2011/65/EU,  
Restriction of Hazardous Substances in EEE.  
RoHS compliance certificate to be provided by supplier.
- 1.4 MAXIMUM PARTLINE MISMATCH AND FLASH 0.05mm.

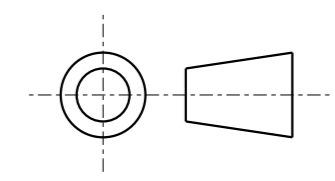

Rev A: 5/5/26 TR - Released for production.

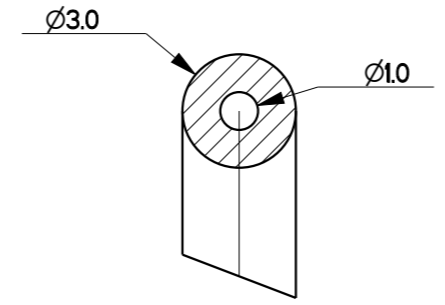

DETAIL A  
SCALE 5.000

*This drawing and design confidential to*  
 © GALLAGHER GROUP LTD  
 Kahikatea Drive, Hamilton,  
 New Zealand.  
 Phone 64 7 838 9800  
 Fax 64 7 838 9801

Dwg No. **4G0979**

Title **ORING-316mm x 3mm  
Hollow SIL S240**

Material **Silicone 40A**

Finish **As Molded**

Unspecified tolerances:

X	±0.5
X.X	±0.2
X.XX	±0.05

Drawn	TR	Date	05-May-2026
-------	----	------	-------------

Approved	PR	Date	06-May-2026
----------	----	------	-------------

Scale	0.33	Drawing Size	A3
-------	------	--------------	----

Sheet 1 of 1 sheets

Issue	PRODUCTION-A	Date	5/5/2026
-------	--------------	------	----------

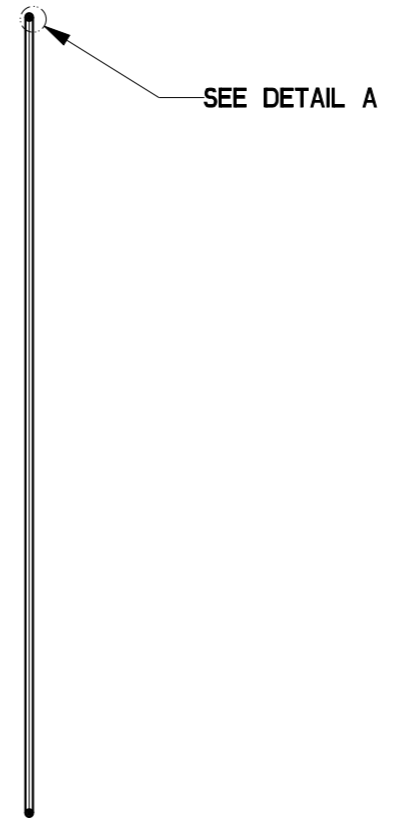
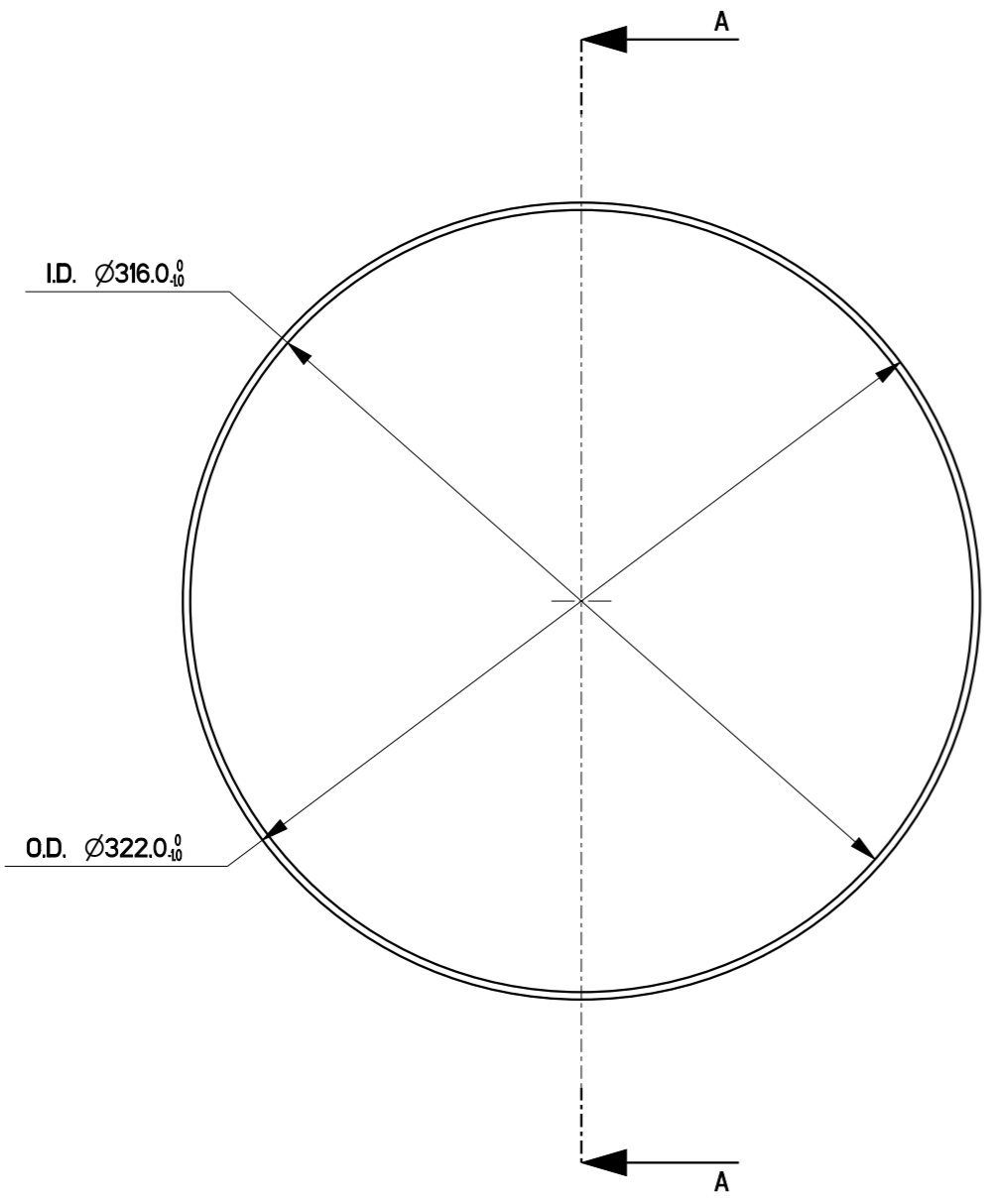

SECTION A-A